

Interface specification

---

OMNIPOWER® HAN

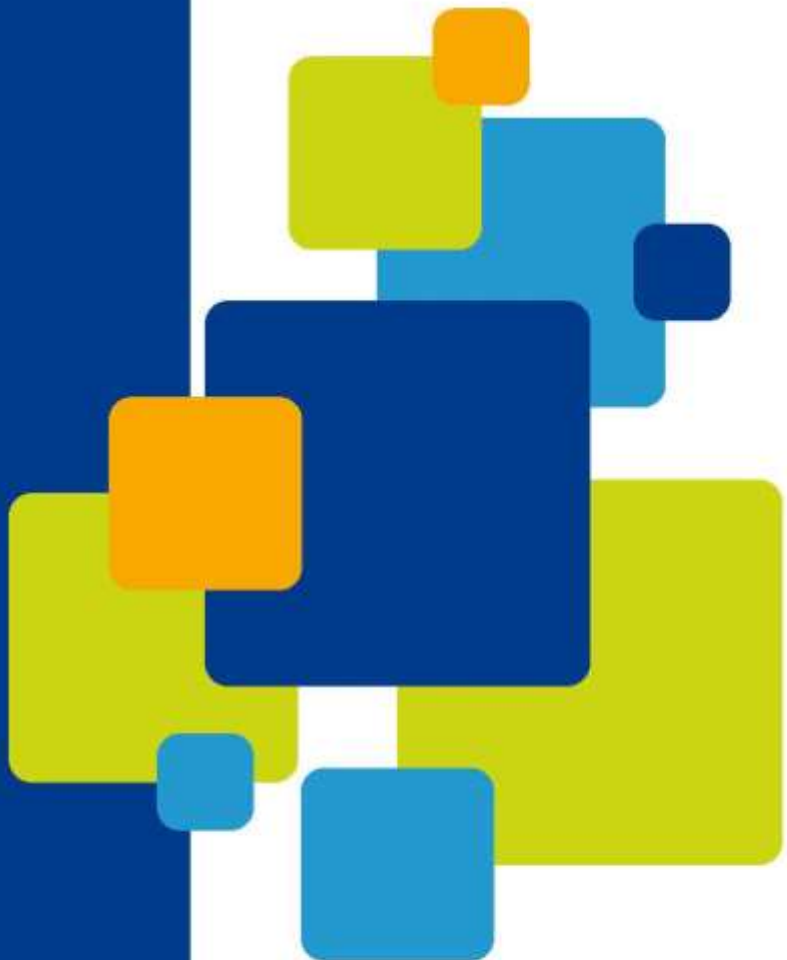

**Disclaimer**

All information provided in this document is copyright of Kamstrup. Licence is granted to the user to freely use and distribute the information in complete and unaltered form, provided that the purpose is to use or evaluate Kamstrup products. Distribution rights do not include public posting or mirroring on Internet websites. Only a link to the Kamstrup website can be provided on such public websites.

Kamstrup shall in no event be liable to any party for direct, indirect, special, general, incidental, or consequential damages arising from the use of this information or any derivative works thereof. The information is provided on an as-is basis, and thus comes with absolutely no warranty, either express or implied. No right or licence is granted under any intellectual property right, hereunder copyright, patent or trademark, of Kamstrup to any other party. This disclaimer includes, but is not limited to, implied warranties of merchantability, fitness for any particular purpose, and non-infringement.

Information in this document is subject to change without notice and should not be construed as a commitment by Kamstrup. While the information contained herein is believed to be accurate, Kamstrup assumes no responsibility for any errors and/or omissions that may appear in this document.

**Copyright Information**

Copyright © Kamstrup A/S  
Industrivej 28  
Stilling  
DK-8660 Skanderborg, Denmark

**All Rights Reserved**

The graphics and content in this document are the copyrighted work of Kamstrup and contain proprietary trademarks and trade names of Kamstrup.

**Third parties**

This document may contain links to other parties. Kamstrup makes no warranty or representation regarding any linked information appearing therein. Such links do not constitute an endorsement by Kamstrup of any such information and are provided only as a convenience. Kamstrup is not responsible for the content or links displayed by third parties.

# Contents

<b>1.</b>	<b>Revision history</b>	<b>4</b>
<b>2.</b>	<b>Introduction</b>	<b>5</b>
<b>3.</b>	<b>OMNIPOWER® HAN interface</b>	<b>6</b>
3.1	Physical HAN port .....	6
3.1.1	HAN module.....	6
3.2	Electrical interface .....	8
<b>4.</b>	<b>Modular HAN interfaces</b>	<b>10</b>
4.1	HAN-NVE module .....	10
<b>5.</b>	<b>HAN push lists</b>	<b>11</b>
5.1	HAN-NVE .....	11
5.1.1	Push data list 1 .....	11
5.1.1.1	Time trigger setup.....	12
5.1.2	Push data list 2 .....	12
5.1.2.1	Time trigger setup.....	12
5.2	DLMS push 1 .....	13
5.2.1	Push data list .....	13
<b>6.</b>	<b>Encryption</b>	<b>15</b>
6.1	Data transport security .....	15
<b>7.</b>	<b>OMNIA® Suite support</b>	<b>16</b>
7.1	OMNISOFT® VisionAir .....	16
7.2	OMNISOFT® Key Management Service.....	17
<b>8.</b>	<b>Related documentation</b>	<b>18</b>

## 1. Revision history

---

Rev.	Description	Meter firmware revision (from and including)
A1	First release of this interface specification.	OMNIPower® firmware number: <ul style="list-style-type: none"><li>• 50981173 rev. AE6</li><li>• 50981165 rev. AE6</li><li>• 50981251 rev. V6</li></ul>
B1	Minor descriptions added: <ul style="list-style-type: none"><li>• Chapter 5 “HAN push lists”: maximum baud rate.</li><li>• Chapter 5.1.2.1 “Time trigger setup”: delay.</li></ul>	OMNIPower® firmware number: <ul style="list-style-type: none"><li>• 50981173 rev. AE6</li><li>• 50981165 rev. AE6</li><li>• 50981251 rev. V6</li></ul>

## 2. Introduction

---

This interface specification describes the OMNIPOWER® Home Area Network (HAN) interface, including supported Kamstrup HAN modules. It also describes the HAN push functionality and the different lists supported.

### **Target group**

This interface specification is mainly intended for persons that are developing reading solutions for connection to the different OMNIPOWER® HAN interfaces.

### 3. OMNIPOWER® HAN interface

---

All OMNIPOWER® meters provide a HAN interface intended for in-home communication for the end-consumers. The HAN interface is used for readout of near real-time data and relevant billing information with both one-way and two-way communication supported.

**Hint** The supported one-way communication is described in Chapter 5 “HAN push lists”.

For more information about two-way communication, please see the technical guide “Kamstrup electricity meter DLMS interface specification” (doc. 5512-2146).

#### 3.1 Physical HAN port

The physical HAN port of an OMNIPOWER® meter is shown below.



Figure 1. OMNIPOWER® HAN port with and without cover

##### 3.1.1 HAN module

The following illustrations provide details about the physical dimensions of a HAN module, including the HAN module PCB.

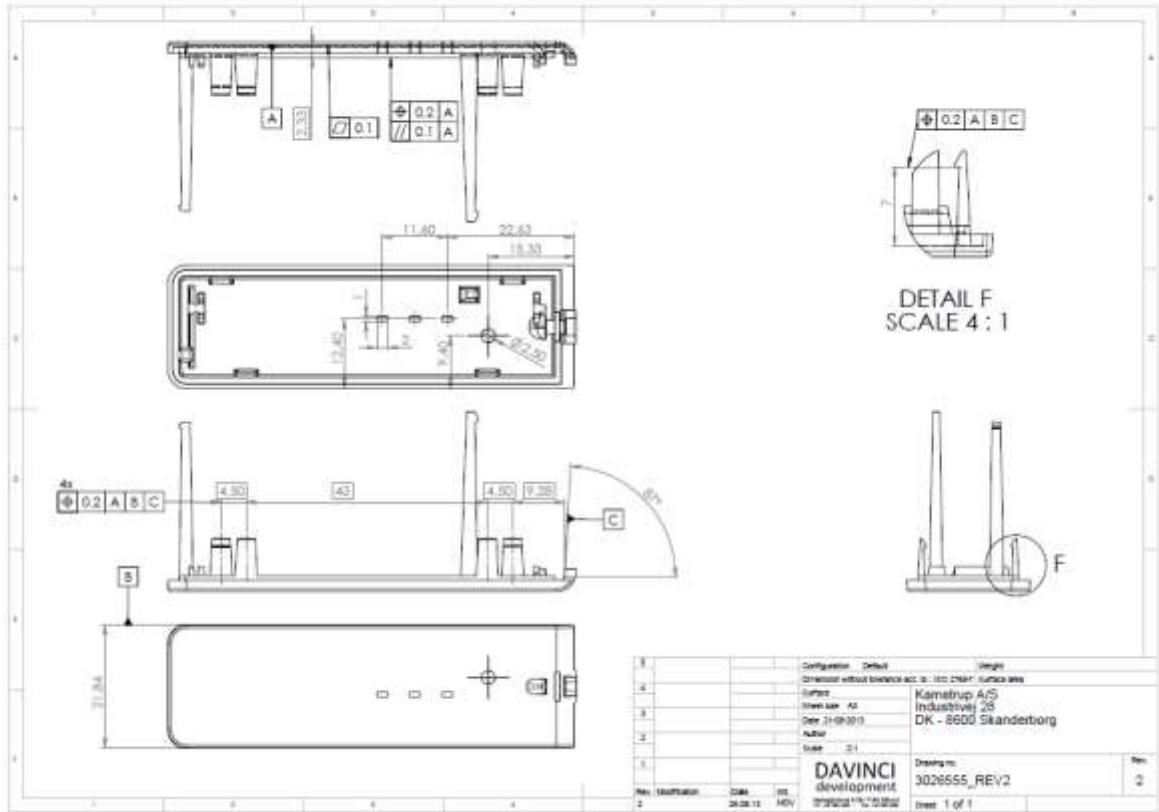

Figure 2. HAN module cover (doc. 3026555)

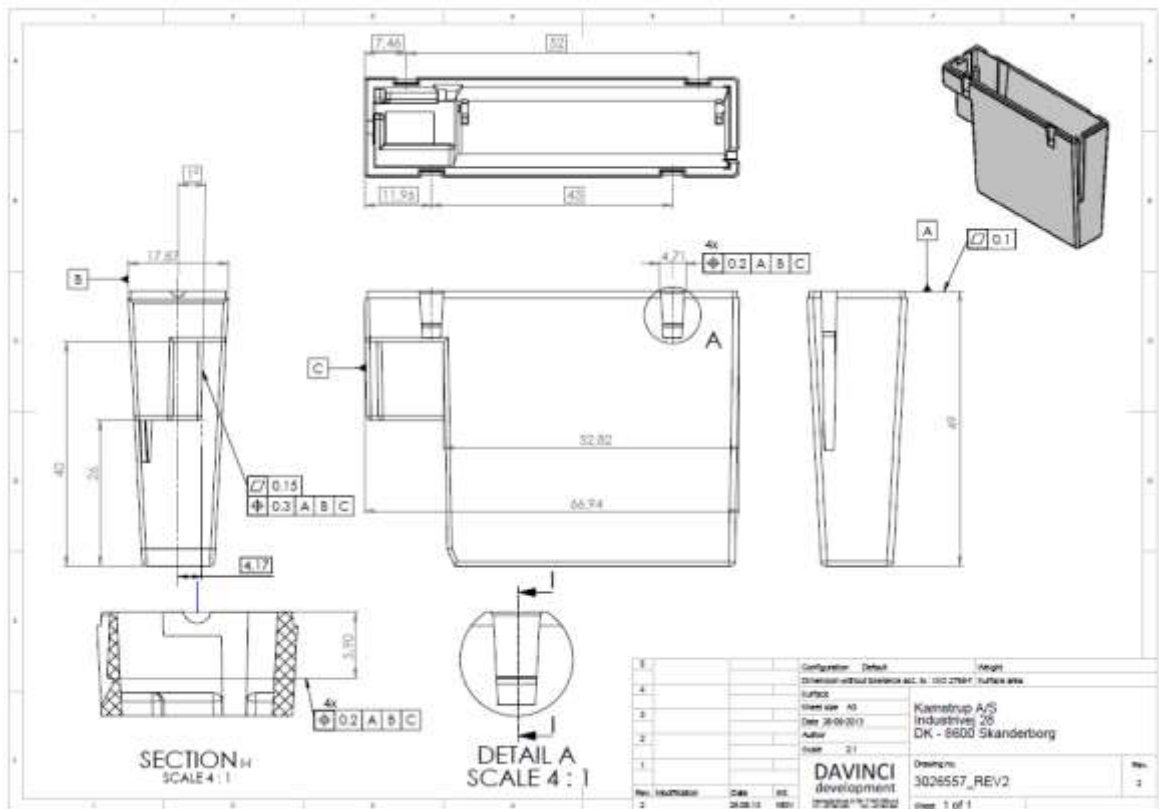

Figure 3. HAN module case (doc. 3026557)

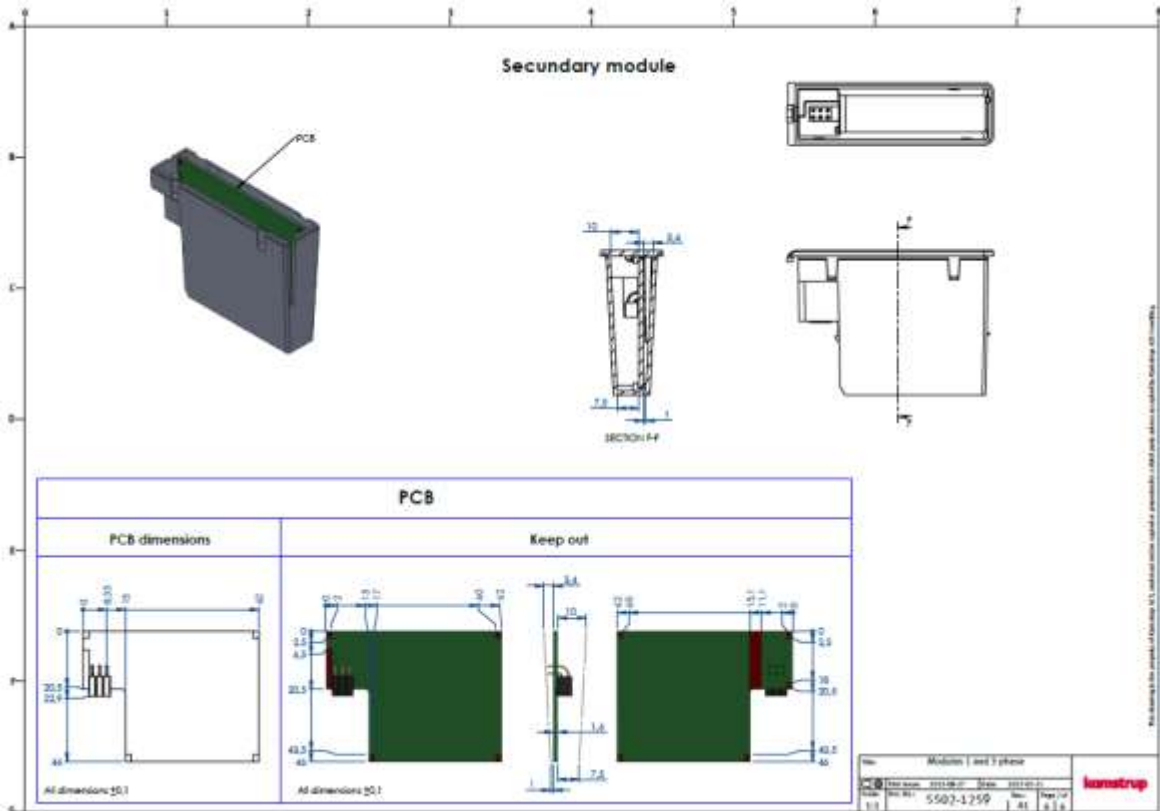

Figure 4. HAN module PCB (doc. 5502-1259)

Please contact Kamstrup A/S if you need the above-mentioned documents.

### 3.2 Electrical interface

The electrical interface of OMNIPOWER® HAN consists of a 6-pin male connector as shown below:

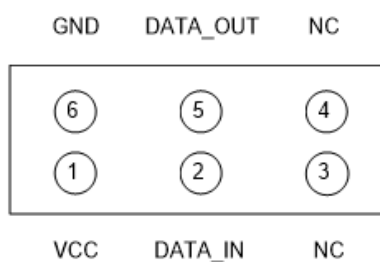

Figure 5. OMNIPOWER® HAN 6-pin male connector

The HAN interface is galvanic isolated from the main terminals and can withstand 4 KV rms for one minute in accordance with EN50470-3 under the following conditions:

Ambient temperature	Main supply
<ul style="list-style-type: none"> <li>• -40°C and +70°C</li> </ul>	<ul style="list-style-type: none"> <li>• 1x230 VAC-20 %- +15 %</li> <li>• 3x230 VAC-20 %- +15 %</li> <li>• 2x230/400 VAC-20 %- +15 %</li> <li>• 3x230/400 VAC-20 %- +15 %</li> </ul>



The pins of the electrical interface have the following characteristics:

Pin	Description
1	VCC <ul style="list-style-type: none"> <li>• Supply output</li> <li>• Nominal voltage: <math>4.15V \pm 0.25V</math>, <math>R_{out} &lt; 0.6</math></li> <li>• Maximum current: 75mA</li> </ul>
2	DATA_IN <ul style="list-style-type: none"> <li>• For serial communication of data to the meter</li> <li>• Maximum baud rate is 9600 bit/s</li> <li>• Internally 82k<math>\Omega</math> pull up to 3.3V</li> <li>• Input, high: minimum 2.0 V / maximum 3.6 V</li> <li>• Input, low: minimum 0 V / maximum 0,8 V</li> </ul>
3	NC <ul style="list-style-type: none"> <li>• Not used</li> </ul>
4	NC <ul style="list-style-type: none"> <li>• Not used</li> </ul>
5	DATA_OUT <ul style="list-style-type: none"> <li>• For serial communication of data from the meter</li> <li>• The highest possible communication speed is 9600 baud</li> <li>• Push/pull: &lt;1.2k<math>\Omega</math> series impedance</li> </ul>
6	GND <ul style="list-style-type: none"> <li>• All signals and supply voltage are referenced to GND</li> </ul>

## 4. Modular HAN interfaces

---

This chapter shortly describes the different OMNIPOWER® HAN modules offered by Kamstrup A/S. Please be aware that several 3rd party HAN modules exist as well.

### 4.1 HAN-NVE module

The HAN-NVE module has been developed to accommodate the Norwegian requirements set by the Norwegian Water Resources and Energy Directorate (Norges Vassdrags- Energidirektorat, NVE).



Figure 6. OMNIPOWER® meter with a HAN-NVE module mounted in the HAN port

The physical interface used is M-Bus, and a RJ-45 connector must be used for connection to the bus. The module is intended for one-way communication, where data is pushed automatically with a predefined interval.

**Hint** For details about:

- how to enable HAN push in OMNIPOWER®, please see Chapter 7.1 “OMNISOFT® VisionAir”.
- the HAN-NVE module, please see the data sheet “HAN module” (doc. 5098-1493).

## 5. HAN push lists

---

This chapter describes the OMNIPower® HAN push functionality and the supported push lists. The HAN push functionality makes it possible to push a predefined data set to the HAN port with a fixed push interval. It is possible to configure whether the HAN push lists should be encrypted or unencrypted. The maximum baud rate is 2400 baud.

**Note** Scaler unit is not part of the push data. Therefore, meter configurations have to be known in order to interpret data correctly.

### 5.1 HAN-NVE

The HAN-NVE push configuration consists of two different data lists with different push intervals:

- [Push data list 1](#)
- [Push data list 2](#)

#### 5.1.1 Push data list 1

The first list of data is pushed out every 10 seconds.

Class	Logical name	Object name	Unit
1	1.1.0.2.129.255	OBIS List version identifier	-
1	1.1.0.0.5.255	GS1 number	-
1	1.1.96.1.1.255	Meter type	-
3	1.1.1.7.0.255	Actual power P14	W
3	1.1.2.7.0.255	Actual power P23	W
3	1.1.3.7.0.255	Actual power Q12	var
3	1.1.4.7.0.255	Actual power Q34	var
3	1.1.31.7.0.255	RMS current of phase L1	A
3	1.1.51.7.0.255	RMS current of phase L2	A
3	1.1.71.7.0.255	RMS current of phase L3	A
3	1.1.32.7.0.255	RMS voltage of phase L1	V
3	1.1.52.7.0.255	RMS voltage of phase L2	V
3	1.1.72.7.0.255	RMS voltage of phase L3	V

### 5.1.1.1 Time trigger setup

- **Push interval:** fixed at 10s, sent at xx:xx:x0 (hh:mm:ss).
- **Priority:** is pushed first (before list 2).

### 5.1.2 Push data list 2

The second list of data is pushed out every hour. It consists of the same data as list 1 plus some extra registers.

Class	Logical name	Object name	Unit
1	1.1.0.2.129.255	OBIS List version identifier	-
1	1.1.0.0.5.255	GS1 number	-
1	1.1.96.1.1.255	Meter type	-
3	1.1.1.7.0.255	Actual power P14	W
3	1.1.2.7.0.255	Actual power P23	W
3	1.1.3.7.0.255	Actual power Q12	var
3	1.1.4.7.0.255	Actual power Q34	var
3	1.1.31.7.0.255	RMS current of phase L1	A
3	1.1.51.7.0.255	RMS current of phase L2	A
3	1.1.71.7.0.255	RMS current of phase L3	A
3	1.1.32.7.0.255	RMS voltage of phase L1	V
3	1.1.52.7.0.255	RMS voltage of phase L2	V
3	1.1.72.7.0.255	RMS voltage of phase L3	V
8	0.1.1.0.0.255	Real-time clock	-
1	1.1.1.8.0.255	Active energy A14	Wh
1	1.1.2.8.0.255	Active energy A23	Wh
1	1.1.3.8.0.255	Reactive energy R12	varh
1	1.1.4.8.0.255	Reactive energy R34	varh

### 5.1.2.1 Time trigger setup

**Push interval:** Fixed at 3600s. The 10 seconds timer and the 1 hour timer must not collide as one of the lists will then not be pushed. Therefore, the 10 seconds timer is sent at xx:xx:x0 (hh:mm:ss) and the 1 hour timer is offset 5 seconds after every whole hour and is sent at xx:00:05 (hh:mm:ss). Further delay is possible in increments of 10 seconds. The hour timer will, in most cases, be sent within 60 seconds. The time stamp will indicate the delay.

## 5.2 DLMS push 1

### 5.2.1 Push data list

The list of data is pushed out every 10 seconds.

Class	Logical name	Object name	Unit
1	1.1.0.2.129.255	OBIS list version identifier	-
3	1.1.1.8.0.255	Active energy A14	Wh
3	1.1.2.8.0.255	Active energy A23	Wh
3	1.1.3.8.0.255	Reactive energy R12	varh
3	1.1.4.8.0.255	Reactive energy R34	varh
1	1.1.0.0.1.255	Meter number 1	-
3	1.1.1.7.0.255	Actual power P14	W
3	1.1.2.7.0.255	Actual power P23	W
3	1.1.3.7.0.255	Actual power Q12	var
3	1.1.4.7.0.255	Actual power Q34	var
8	0.1.1.0.0.255	Real-time clock	-
3	1.1.32.7.0.255	RMS voltage of phase L1	V
3	1.1.52.7.0.255	RMS voltage of phase L2	V
3	1.1.72.7.0.255	RMS voltage of phase L3	V
3	1.1.31.7.0.255	RMS current of phase L1	A
3	1.1.51.7.0.255	RMS current of phase L2	A
3	1.1.71.7.0.255	RMS current of phase L3	A
3	1.1.21.7.0.255	Actual power P14 of phase L1	W
3	1.1.41.7.0.255	Actual power P14 of phase L2	W
3	1.1.61.7.0.255	Actual power P14 of phase L3	W
3	1.1.33.7.0.255	Power factor of phase L1	-
3	1.1.53.7.0.255	Power factor of phase L2	-
3	1.1.73.7.0.255	Power factor of phase L3	-
3	1.1.13.7.0.255	Power factor Total	-
3	1.1.22.7.0.255	Active power P23 of phase L1	W
3	1.1.42.7.0.255	Active power P23 of phase L2	W
3	1.1.62.7.0.255	Active power P23 of phase L3	W

Class	Logical name	Object name	Unit
3	1.1.22.8.0.255	Active energy A23 of phase L1	Wh
3	1.1.42.8.0.255	Active energy A23 of phase L2	Wh
3	1.1.62.8.0.255	Active energy A23 of phase L3	Wh
3	1.1.21.8.0.255	Active energy A14 of phase L1	Wh
3	1.1.41.8.0.255	Active Energy A14 of phase L2	Wh
3	1.1.61.8.0.255	Active Energy A14 of phase L3	Wh

## 6. Encryption

---

OMNIPOWER® supports full encryption on all communication interfaces, including the HAN interface.

Each meter holds a number of keys, called general purpose keys (GPK), used for role-based access. OMNIPOWER® has a customer role intended for use with the HAN interface, as only read-access to a predefined set of registers is permitted. The customer role is implemented for GPK60, used for encryption, and GPK61, used for authentication.

### 6.1 Data transport security

The supported data security mechanism(s) used for data transport is:

- Data transport with AES-GCM-128 and key transport AES-128 key wrap (DLMS/COSEM suite 0).

The supported data transport protection is:

- xDLMS APDU encryption and authentication using the “general-glo-ciphering” service (global keys).

## 7. OMNIA® Suite support

---

This chapter provides an overview of the different HAN push related functionalities supported by OMNIA® Suite.

### 7.1 OMNISOFT® VisionAir

The following OMNIPOWER® HAN configurations are available in OMNISOFT® VisionAir (**Meter > Configurations > HAN tab**):

- Enable/disable HAN push
- Enable/disable encryption of HAN push
- Push list configuration

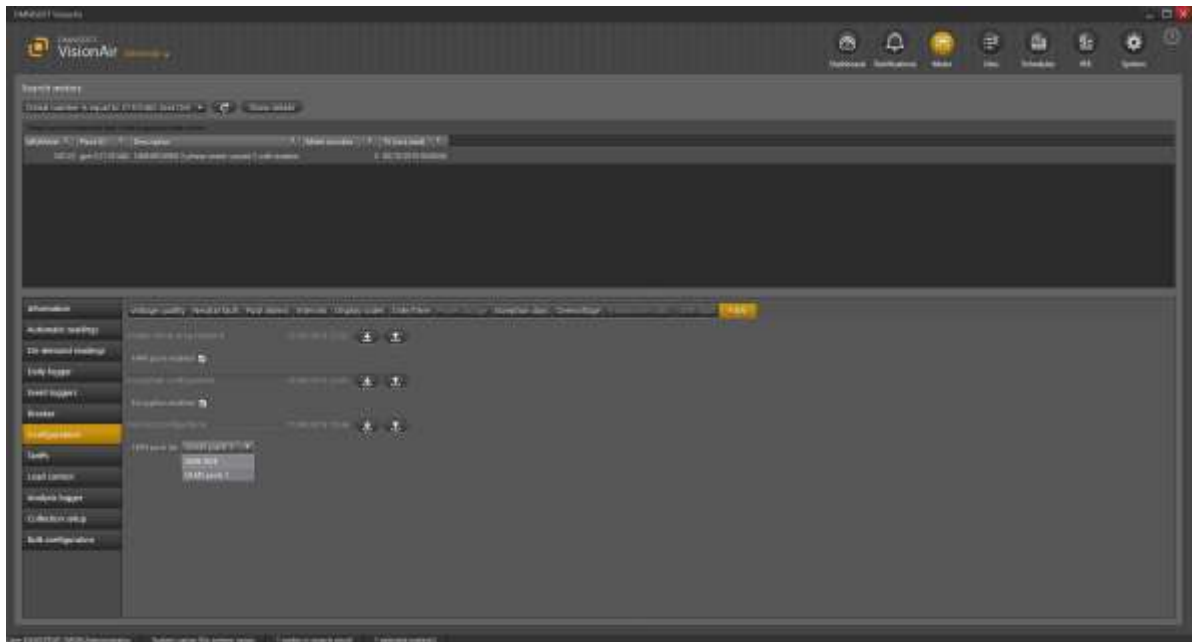

Figure 7. HAN configurations in OMNISOFT® VisionAir

As default, all configurations are disabled. Enabling of the HAN push functionality must be done from OMNISOFT® VisionAir (by selecting the **HAN push enabled** check box).



**Note** When the HAN push functionality is enabled, the HAN interface is exclusively used for pushing data. Consequently, the HAN port works as transmit (Tx) only, i.e. no receive requests (Rx) of any protocol is supported.

Enabling/disabling of encryption and push list configuration are only supported from the following meter firmware and forward:

- 50981173 AE6
- 50981165 AE6
- 50981251 V6

Older meter firmware only supports enabling/disabling of HAN push and will always enable the HAN-NVE push list.

## 7.2 OMNISoft® Key Management Service

OMNISoft® Key Management Service can be used to derive and export encryption keys, including GPK60 and GPK61 intended for the HAN interface.

**Hint** For details about how to export encryption keys, please see “Exporting encryption keys” in the user guide “OMNISoft® Key Management Service” (doc. 5512-1721).

OMNISoft® Key Management Service exports encryption keys in a password protected Kamstrup Encryption Meter file (KEM file), which can be unpacked if the keys are needed in clear text.

**Hint** For details about how to unpack KEM-files, please see the how-to guide “Deriving encryption keys for HAN-modules” (doc. 5512-2531).

## 8. Related documentation

---

Please refer to the following manuals for additional information:

- Data sheet “HAN module” (doc. 5098-1493).
- Interface specification “HAN-NVE module” (5512-2441).
- Technical guide “Kamstrup electricity meter DLMS interface specification” (doc. 5512-2146).
- How-to guide “Deriving encryption keys for HAN-modules” (doc. 5512-2531).
- User guide “OMNISoft® Key Management Service” (doc. 5512-1721).